



**Hidro
Pnevmo
Tehnika**

3, Vojeli St., Kazanlak, Bulgaria
Tel.: +359 431/ 62 228, 68 440
e-mail : info@hpt-bg.com
www.hpt-bg.com

HYDRAULIC MOTOR BLOCKS TYPE BV

BVS .. 07

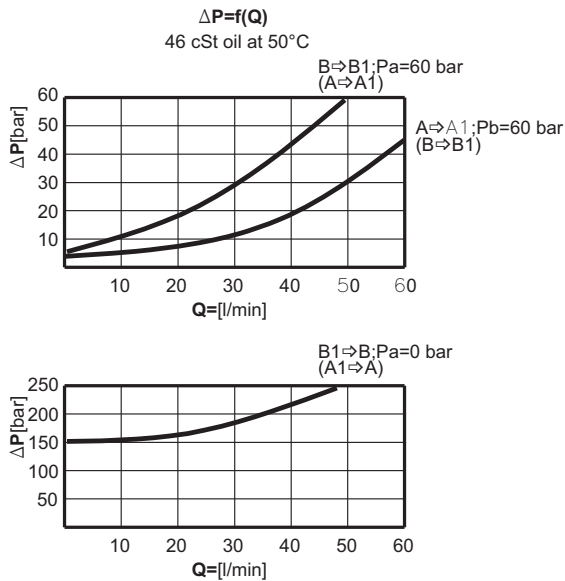
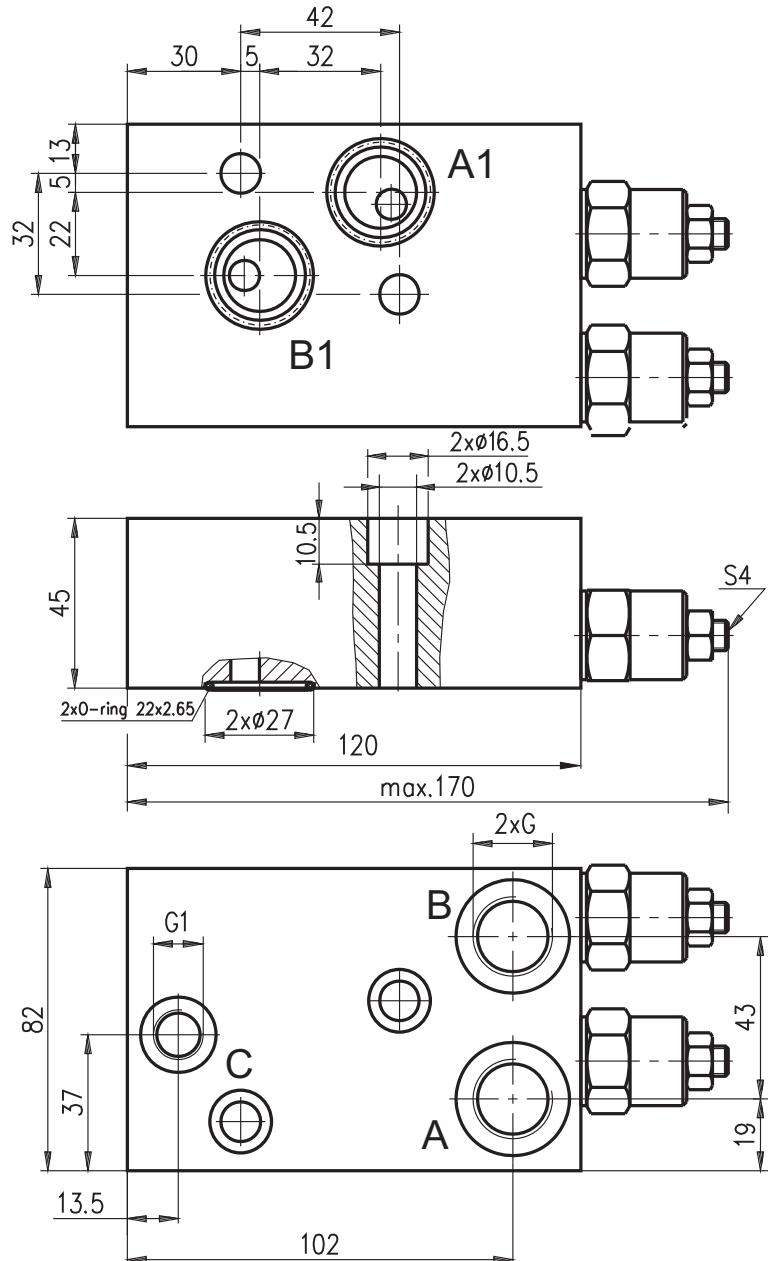
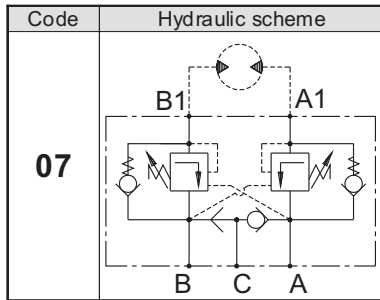

| Type | Nominal flow rate | Adj. pressure range | Pressure ratio | P _{max.} | Port threads G | Port threads G1 |
|-----------------|-------------------|---------------------|----------------|-------------------|-----------------------|------------------------|
| | L/min | bar | - | bar | - | - |
| BVS 1207 | 60 | 60...250 | 4,25:1 | 250 | G1/2 - DIN 3852 | G1/4 - DIN 3852 |
| BVS 7807 | 60 | 60...250 | 4,25:1 | 250 | 7/8-14UNF - ISO 11926 | 7/16-20UNF - ISO 11926 |
| BVS 2207 | 60 | 60...250 | 4,25:1 | 250 | M22x1,5 - DIN 3852 | M14x1,5 - DIN 3852 |

ORDERING CODE

BV S 12 07

