



**Hidro
Pnevmo
Tehnika**

3, Vojeli St., Kazanlak, Bulgaria
Tel.: +359 431/ 62 228, 68 440
e-mail: info@hpt-bg.com
www.hpt-bg.com

RELIEF VALVE

CPL160/1-..

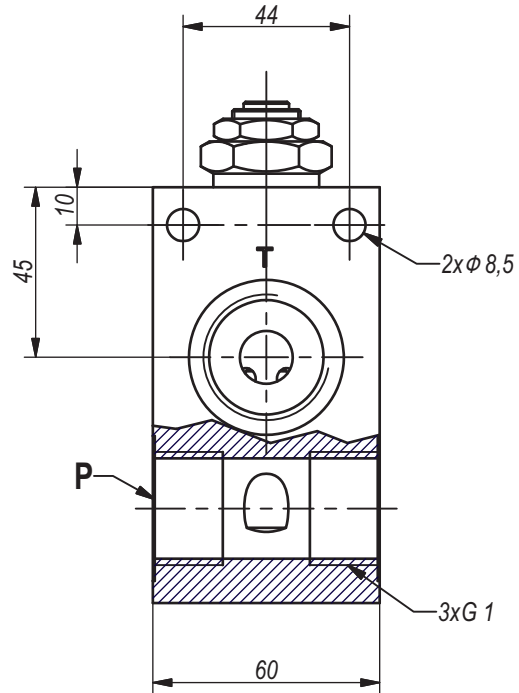
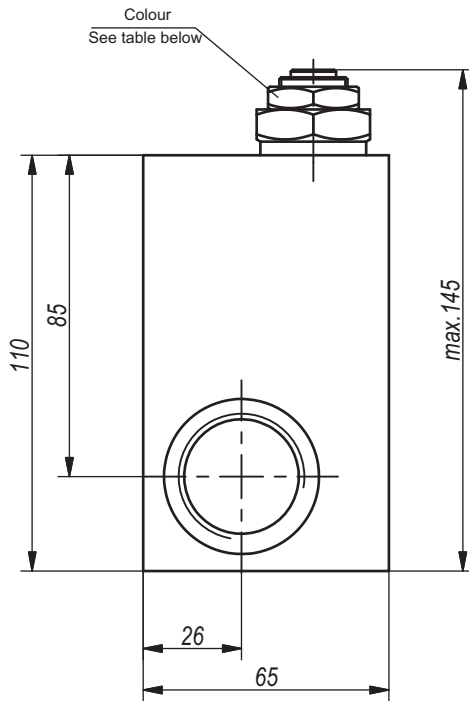
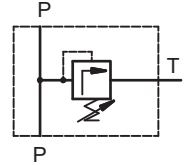

$\Delta P = f(Q)$

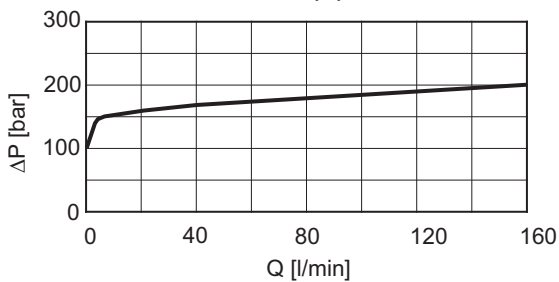

Type	P _{max.} bar	Q _{nom.} L/min
CPL160/1-..	320	160

Code	Pressure range		Colour
	Adj. pressure range bar	Standard setting (Q=5 L/min) bar	
10	5...100	80	White
20	15...200	180	Yellow
32	20...320	250	Black

Note: 1. All performances and calibrations are carried out by using hydraulic oil with viscosity approx. 46 cSt at 50°C
2. Working fluid: Viscosity - 10...100 mm²/s. Temperature range:-20°C...+80°C. Filtration absolute: 25 μm.

ORDERING CODE

CPL160/1 - ..

