



**Hidro  
Pnevmo  
Tehnika**

3, Vojeli St., Kazanlak, Bulgaria  
Tel.: +359 431/ 62 228, 68 440  
e-mail: info@hpt-bg.com  
www.hpt-bg.com

## HYDRAULIC DRIVEN BOOSTER

MLV .../...

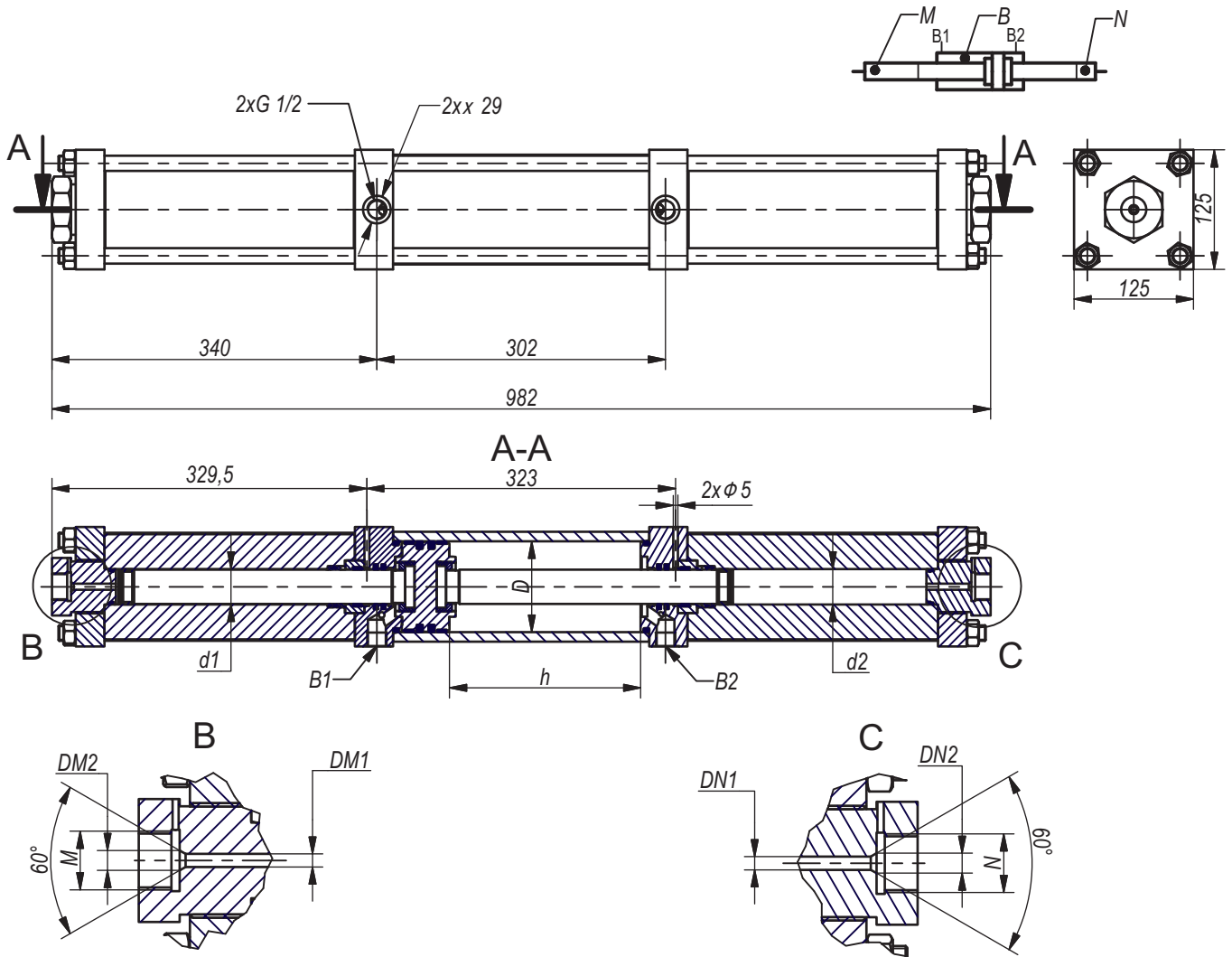
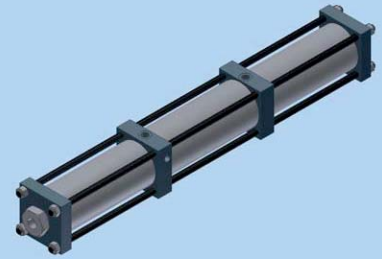

Actuating liquid in chamber "B" - hydraulic oil with a viscosity 20...400 cSt.  
Working fluid in chambers "N" and "M" - 5% water and oil emulsion.

Type	Port threads M	Port threads N	D	d1	d2	Stroke of the piston h	Qnom B1, B2	Pmax B1, B2	port N	Pmax port M	DM1	DM2	DN1	DN2
			[mm]	[mm]	[mm]	[mm]	[l/min]	[bar]	[bar]	[bar]	[mm]	[mm]	[mm]	[mm]
MLV 118U/118U	1 1/8-12 UNF	1 1/8-12 UNF	95	36	36	200	40	270	1590	1590	6,4	9,7	6,4	9,7

### ORDERING CODE

**MLV 118U / 118U**

