



**Hidro  
Pnevmo  
Tehnika**

3, Eng. Felix Vozhely St.,  
6100 Kazanlak, Bulgaria  
Tel.: +359 431 62 228  
+359 431 68 440  
e-mail: [info@hpt-bg.com](mailto:info@hpt-bg.com)  
[www.hpt-bg.com](http://www.hpt-bg.com)

## VALVE BLOCKS

### BPC5/ . . .

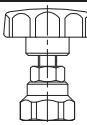
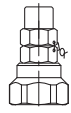

All performances and calibration are carried out by using hydraulic oil with viscosity approx. 32 cSt at 50 °C  
Temperature range: -20 °C...+80 °C.  
Filtration absolute: 20 µm

Code	Adjustment
<b>A</b>	Leakproof hex. socket screw 
<b>B</b>	Handknob and locknut 
<b>C</b>	Sealing cap 

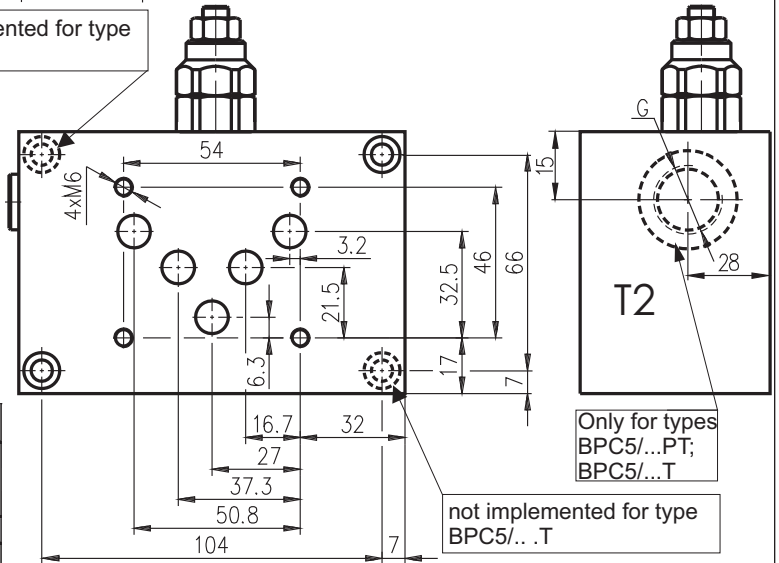
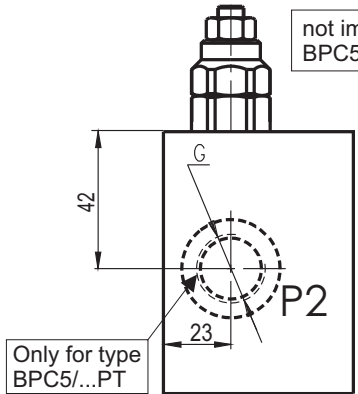
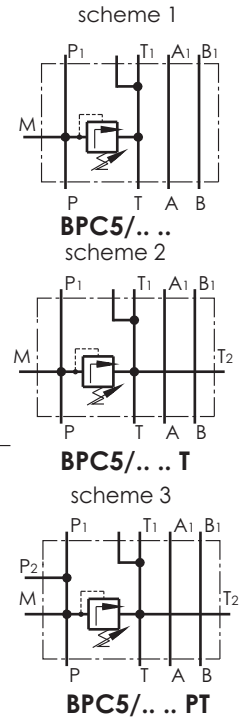
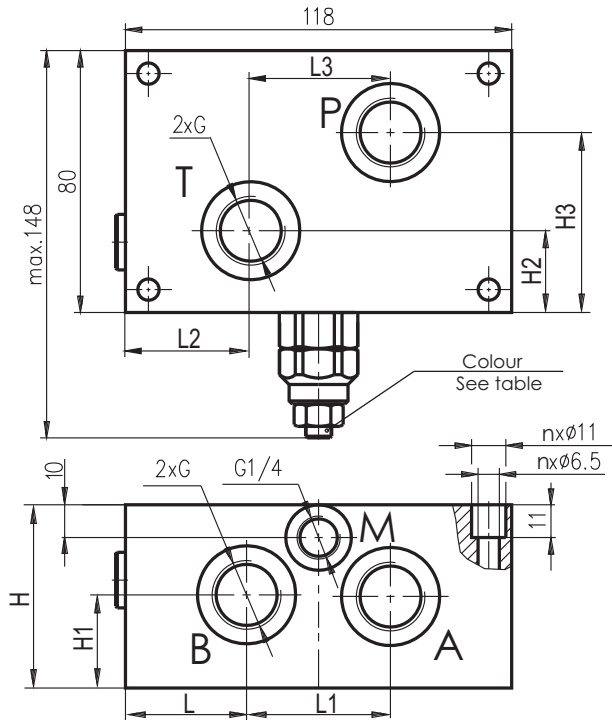

Pressure range			
Code	Standard setting bar (Q=5l/min)	Adj. pressure range bar	Colour
<b>10</b>	80	10...100	White
<b>25</b>	180	30...250	Yellow
<b>35</b>	250	70...350	Black

Type	P <sub>max.</sub>	Q <sub>max.</sub>	H	H1	H2	H3	L	L1	L2	L3	G	n
	bar	L/min	mm	mm	mm	mm	mm	mm	mm	mm	-	pcs
<b>BPC5/... .</b>	350	80	58	30,5	25	55	37	44	37	44	G1/2"	4
<b>BPC5/... . T</b>	350	80	58	30,5	25	55	37	44	37	44	G1/2"	2
<b>BPC5/... . PT</b>	350	80	68	36	27	56	34	50	37	41	G3/4"	4

### ORDERING CODE

#### BPC5 / 25 A T

