



**Hidro
Pnevmo
Tehnika**

3, Vojeli St., Kazanlak, Bulgaria
Tel.: +359 431/62 228
Fax.: +359 431/62 019
e-mail: info@hpt-bg.com
www.hpt-bg.com

HYDRAULIC MOTOR BLOCKS TYPE BD

BDMH 3809

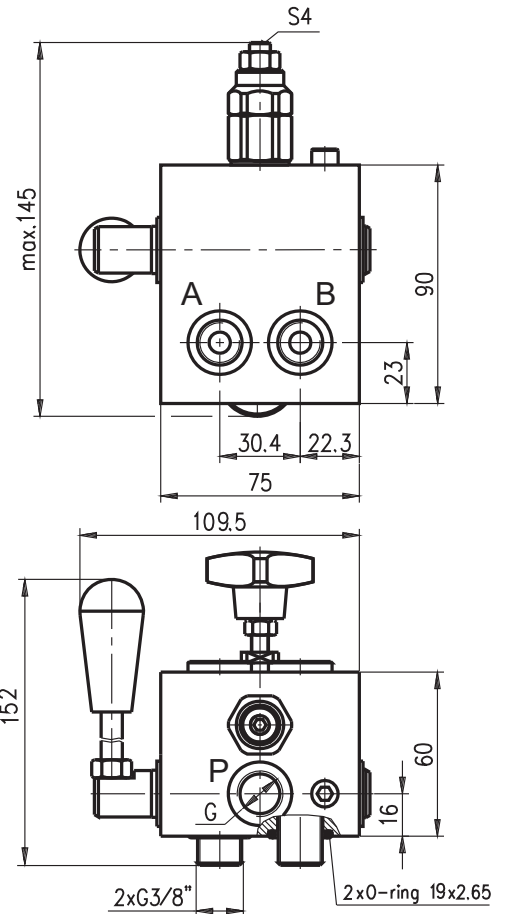
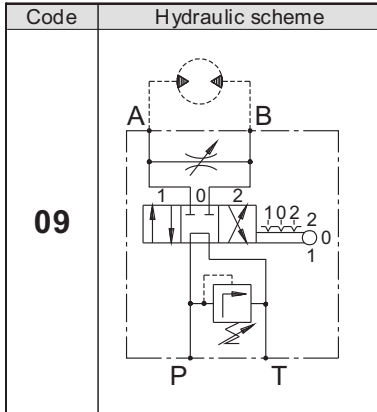

Pressure range			
Code	Standard setting (Q=5l/min)	Adj. pressure range	Colour
	bar	bar	
10	80	10...100	White
25	180	30...250	Yellow

Code	Adjustment
A	Leakproof hex. socket screw
B	Handknob and locknut
C	Sealing cap

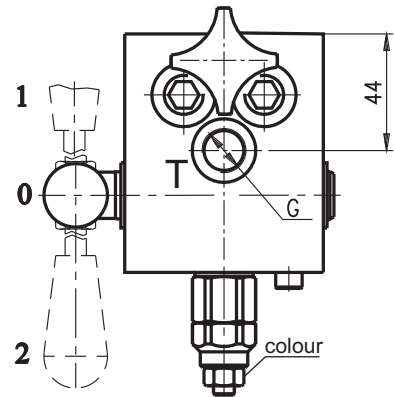
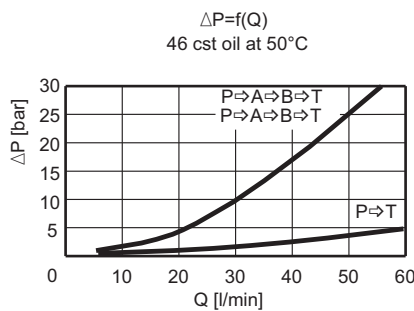

Type	Nom. flow rate	P _{max.}	Port threads G
	L/min	bar	-
BDMH 3809 . / . .	30	250	G3/8 - DIN 3852

ORDERING CODE

BD M H 38 09 L / 10 A

