



**Hidro
Pnevmo
Tehnika**

3, Vojeli St., Kazanlak, Bulgaria
Tel.: +359 431/ 62 228, 68 440
e-mail: info@hpt-bg.com
www.hpt-bg.com

HYDRAULIC MOTOR BLOCKS TYPE BD

BDR 1204 . / ...

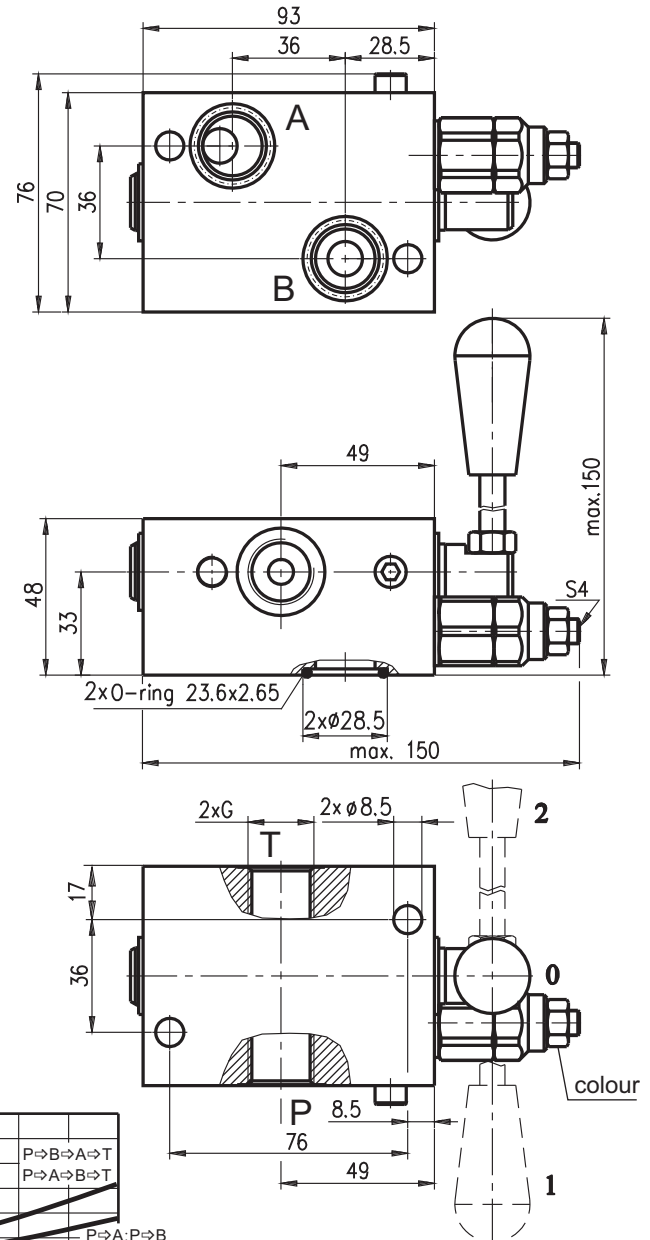
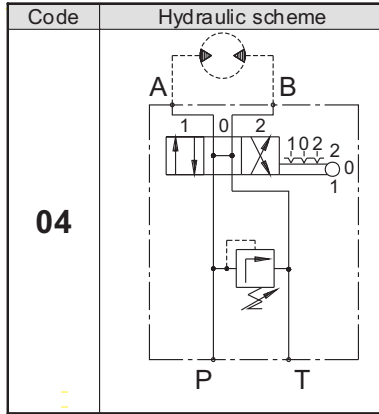
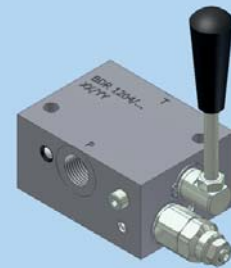

Pressure range			
Code	Standard setting (Q=5l/min)	Adj. pressure range	Colour
	bar	bar	-
10	80	10...100	White
25	180	30...250	Yellow

Code	Adjustment
A	Leakproof hex. socket screw
B	Handknob and locknut
C	Sealing cap

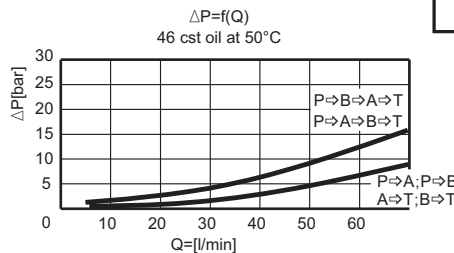

Type	Nom. flow rate	P _{max.}	Port threads G
	L/min	bar	-
BDR 1204 . / ...	60	250	G1/2 - DIN 3852

ORDERING CODE

BD R 12 04 L / 10 A

Type

Hydraulic motor type - code:
MP or MR - **R**

Scheme code:
04

Adjustment code:
A; B; C
(see table above)

Port threads G - code:
G1/2 - **12**

Body material - code:
Aluminium - **Omit**
Brass - **L**

Pressure range code:
10; 25