



**Hidro
Pnevmo
Tehnika**

3, Vojeli St., Kazanlak, Bulgaria
Tel.: +359 431/62 228
Fax.: +359 431/62 019
e-mail: info@hpt-bg.com
www.hpt-bg.com

HYDRAULIC MOTOR BLOCKS TYPE BD

BDR 1207/... ..

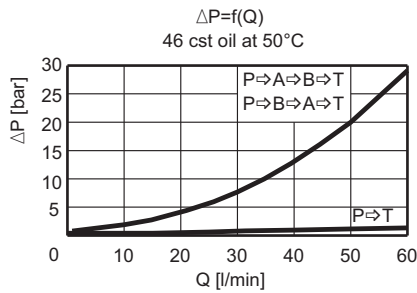
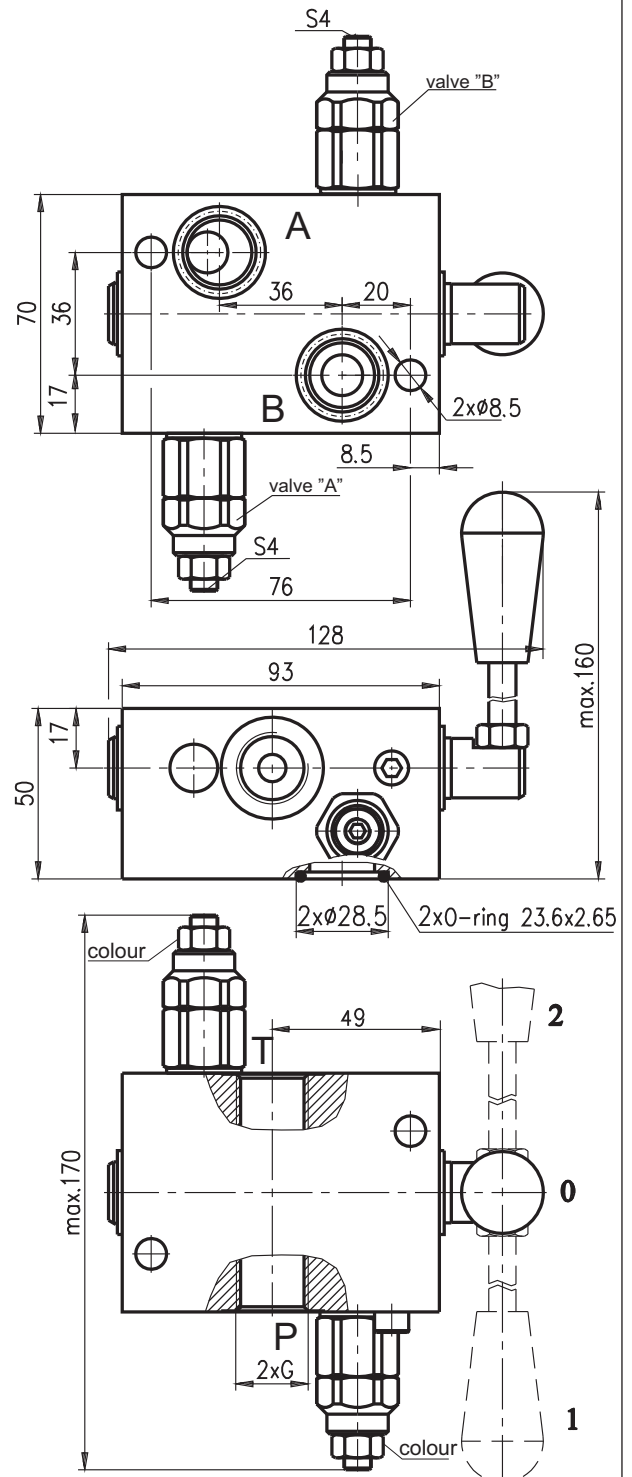
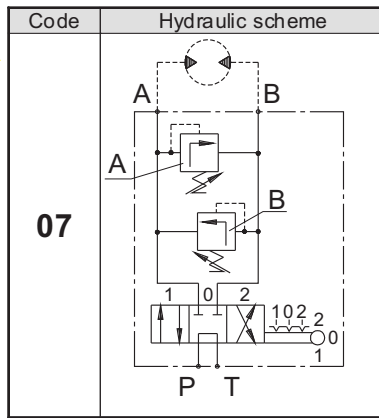
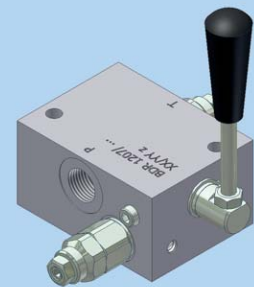

Code	Adjustment
A	Leakproof hex. socket screw
C	Sealing cap

Type	Nom. flow rate	$P_{max.}$	Port threads G
	L/min	bar	-
BDR 1207 /... ..	60	250	G12 - DIN 3852

Pressure range			
Code	Standard setting (Q=5l/min)	Adj. pressure range	Colour
	bar	bar	-
10	80	10...100	White
25	180	30...250	Yellow

ORDERING CODE

BD R 12 07 / A10 A - B25 A

Type

Hydraulic motor type - code:
MP or MR
- **R**

Port threads G - code:
G1/2
- **12**

Code scheme:
07

Adjustment code:
A; C
(see table above)

Pressure range
valve "A"-code:
10; 25

Adjustment code:
A; C
(see table above)

Pressure range
valve "B"-code:
10; 25