

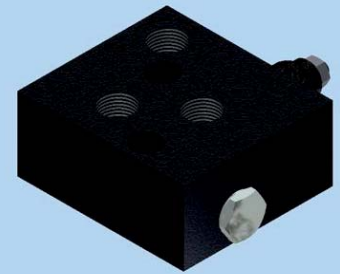

**Hidro
Pnevmo
Tehnika**



3, Vojeli St., Kazanlak, Bulgaria
Tel.: +359 431/62 228
Fax.: +359 431/62 019
e-mail: info@hpt-bg.com
www.hpt-bg.com

HYDRAULIC MOTOR BLOCKS TYPE BD

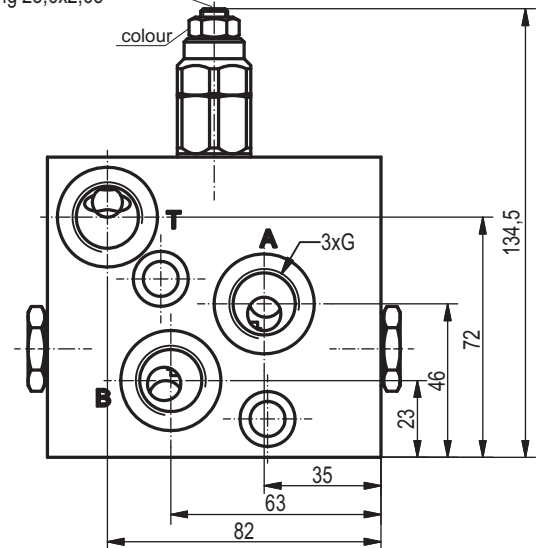
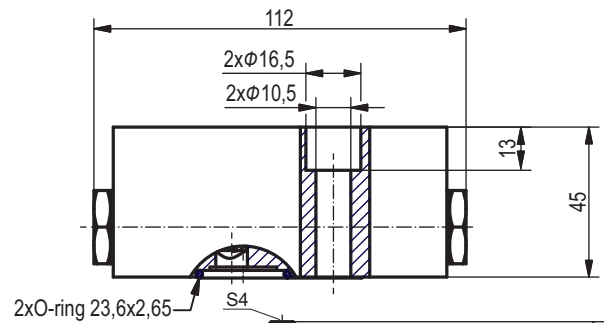
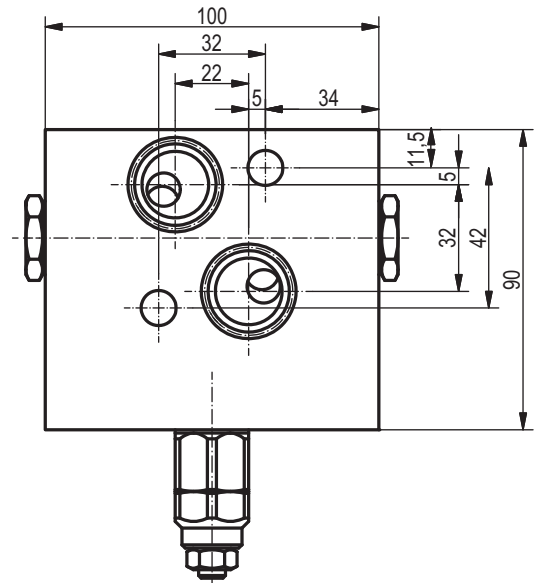
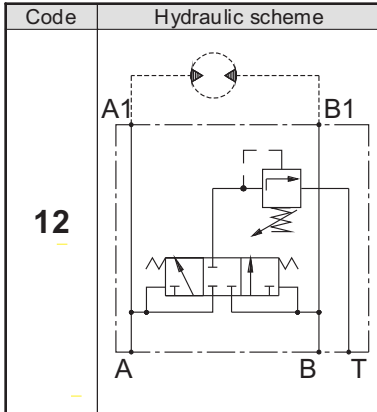

BDS 1212



Code	Adjustment
A	Leakproof hex. socket screw 
C	Sealing cap 

Type	Nom. flow rate	P _{nom.}	Port threads G
	L/min	bar	-
BDS 1212	40	210	G1/2 - DIN 3852

Pressure range			
Code	Standard setting (Q=5l/min)	Adj. pressure range	Colour
	bar	bar	-
10	80	10...100	White
25	180	30...250	Yellow

ORDERING CODE

BD S 12 12 / 25 A

