



**Hidro
Pnevmo
Tehnika**

3, Vojeli St., Kazanlak, Bulgaria
Tel.: +359 431/ 62 228, 68 440
e-mail : info@hpt-bg.com
www.hpt-bg.com

HYDRAULIC MOTOR BLOCKS TYPE BV



BVR 12 18/A... - B...

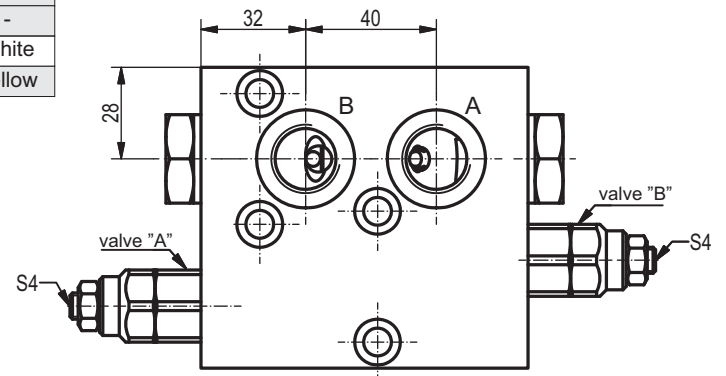
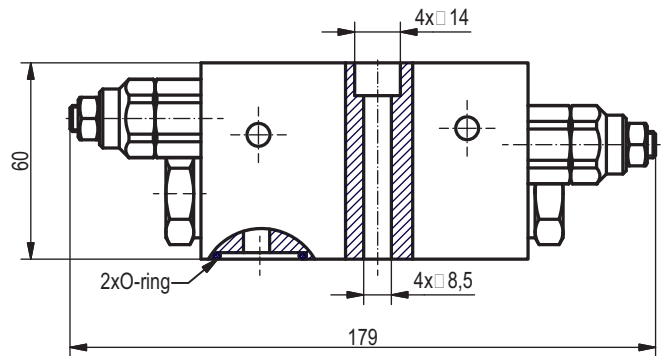
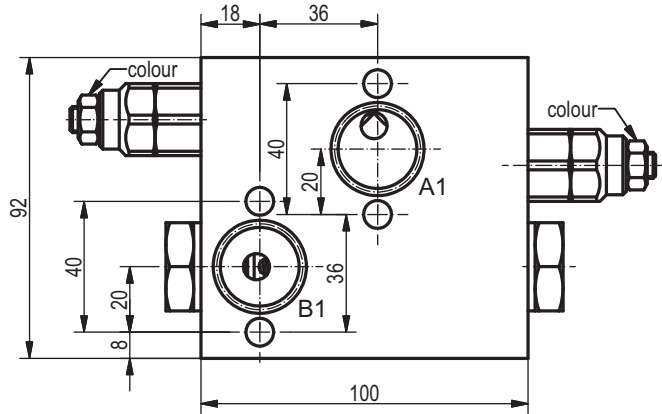
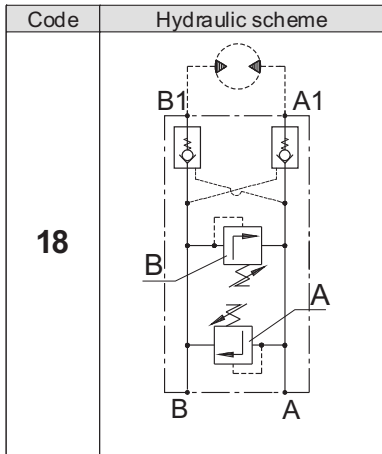

Pressure range			
Code	Standard setting (Q=5l/min)	Adj. pressure range	Colour
	bar	bar	
10	80	10...100	White
25	180	30...250	Yellow

Code	Adjustment
A	Leakproof hex. socket screw
B	Handknob and locknut
C	Sealing cap

Type	Flow rate max.	Pilot ratio	Pmax.	Port threads G	O-Ring
	L/min	-	bar	-	-
BVR 1218/A...-B...	30	5:1	250	G1/2 - DIN 3852	23,6x2,65

ORDERING CODE

BV R 12 18 / A10 A - B25 A

