

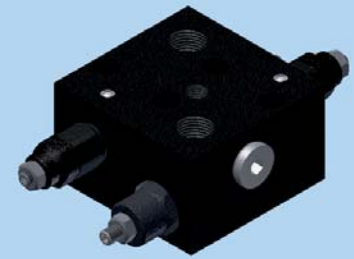

**Hidro
Pnevmo
Tehnika**

3, Vojeli St., Kazanlak, Bulgaria
Tel.: +359 431/ 62 228, 68 440
e-mail : info@hpt-bg.com
www.hpt-bg.com

HYDRAULIC MOTOR BLOCKS TYPE BV



BVR 12 19/.. .-.. .

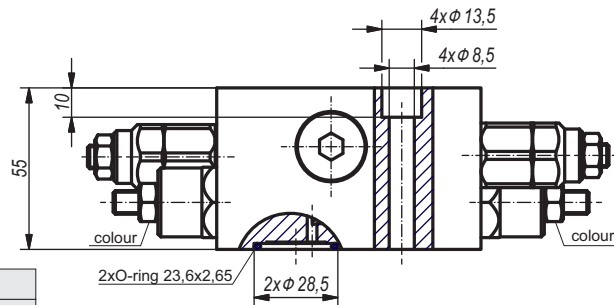
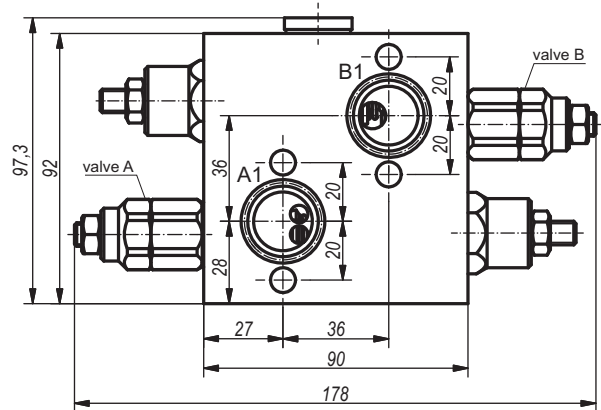
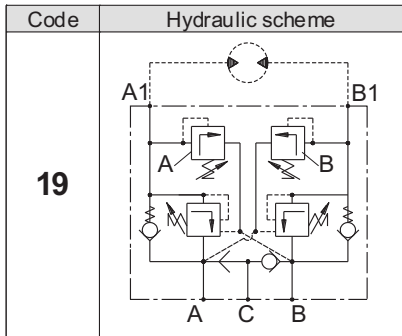

Pressure range relief valve			
Code	Standard setting (Q=5l/min)	Adj. pressure range	Colour
	bar	bar	
10	80	10...100	White
25	180	30...250	Yellow

Code	Adjustment
A	Leakproof hex. socket screw
B	Handknob and locknut
C	Sealing cap

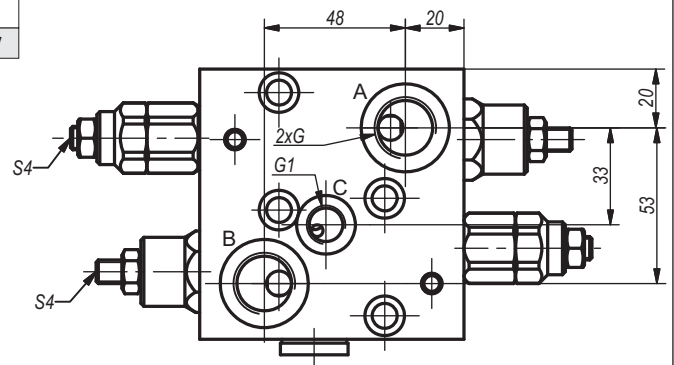

Type	Nominal flow rate	Adj. pressure range overcenter valve	Pressure ratio overcenter valve	Pmax.	Port threads G	Port threads G1
	L/min	bar	-	bar	-	-
BVR 1219	50	60...250	4,25:1	250	G1/2 - DIN 3852	G1/4 - DIN 3852

ORDERING CODE

BV R 12 19 / A10 A - B25 A

Type

Hydraulic motor type - code:
MP or MR - R

Port threads G - code
G1/2 - 12

Scheme code:
09

Adjustment code:
A; B; C
(see table above)

Pressure range code
valve "A":
10; 25

Adjustment code:
A; B; C
(see table above)

Pressure range code
valve "B":
10; 25