

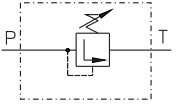



 Page 2.1	KPZ .. / .. 
 Page 2.3	KPPZ 10-1/.. 
 Page 2.4	CPL .. / .. / .. 
 Page 2.5	CPL160/1-.. 
 Page 2.6	RV-NS32/.../... 

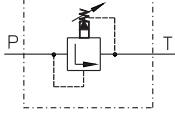

**Hidro
Pnevmo
Tehnika**

3, Vojeli St., Kazanlak, Bulgaria
Tel.: +359 431/ 62 228, 68 440
e-mail: info@hpt-bg.com
www.hpt-bg.com

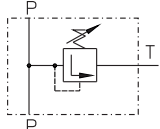
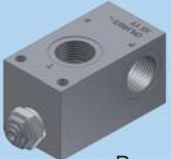
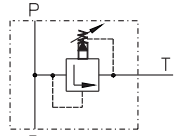
CARTRIDGE RELIEF VALVE

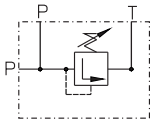
KPZ .. / ..



KPZ 10/.. A

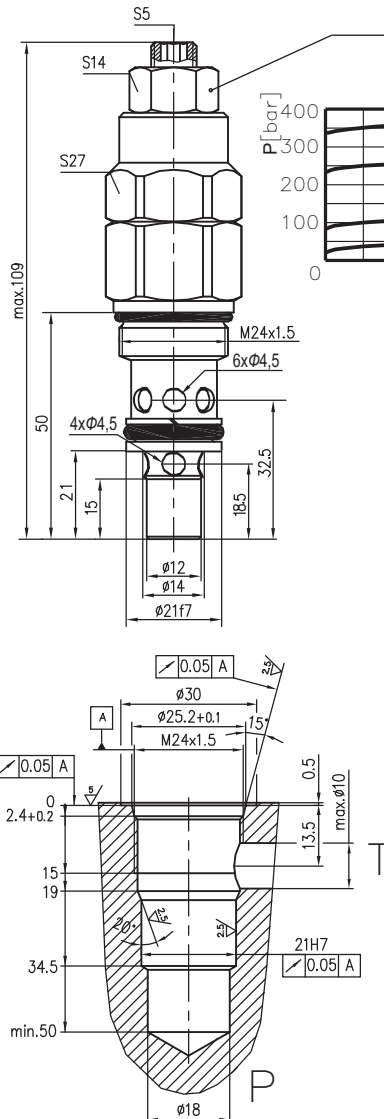

Type	P _{max}	
	bar	L/min
KPZ6/..	350	40
KPZ10/..	350	80

Code	Pressure range		Colour
	Adj. pressure range	Standard setting (Q=5 L/min)	
10	10...100	80	White
25	30...250	180	Yellow
35	70...350	250	Black

KPZ 6/.. A

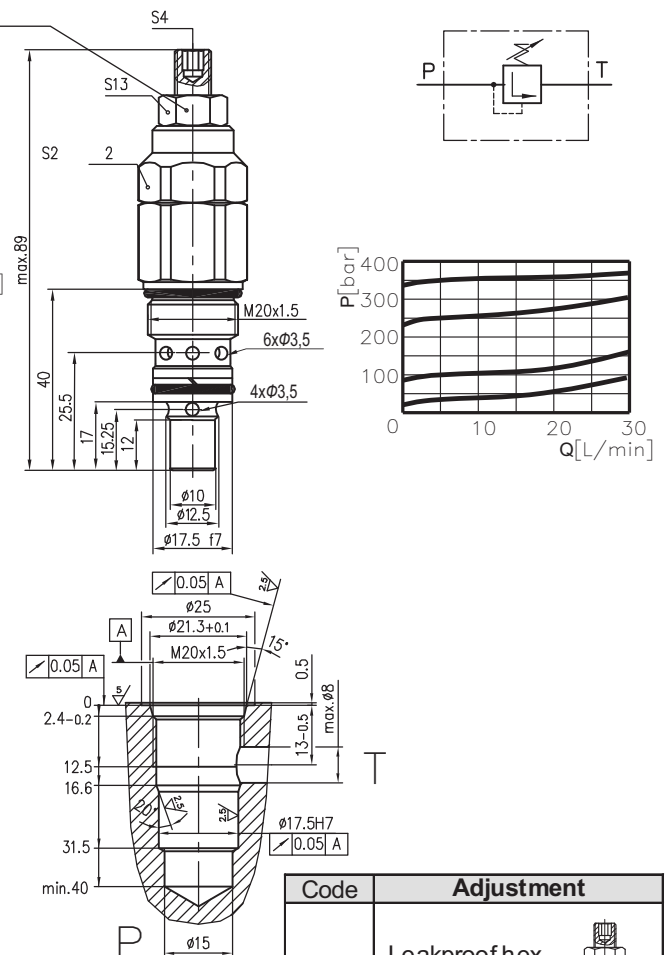

Code	Adjustment
A	Leakproof hex. socket screw
B	Handknob and locknut
C	Sealing cap

Note: 1. All performances and calibrations are carried out by using hydraulic oil with viscosity approx. 32 cSt at 50°C
2. Tightening torque: 35 N.m.
3. Body coating – Zn.
4. Working fluid: Viscosity - 10...100 mm²/s. Temperature range:-20°C...+80°C. Filtration absolute: 25 µm.

ORDERING CODE

KPZ 6 / 10 A

Type

Pressure range code: **10; 25; 35**

Adjustment code: **A; B; C**



**Hidro
Pnevmo
Tehnika**

3, Vojeli St., Kazanlak, Bulgaria
Tel.: +359 431/ 62 228, 68 440
e-mail: info@hpt-bg.com
www.hpt-bg.com

CARTRIDGE RELIEF VALVE

KPZ ... / ...



KPZ 12/.. A

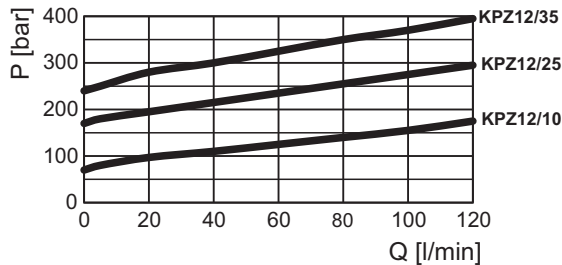
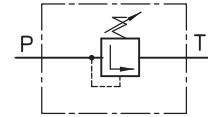
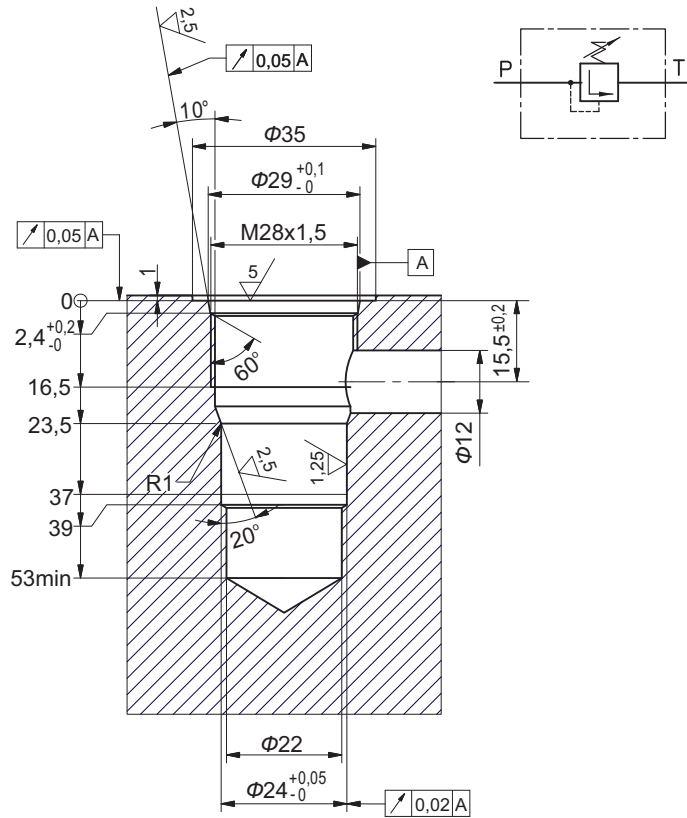
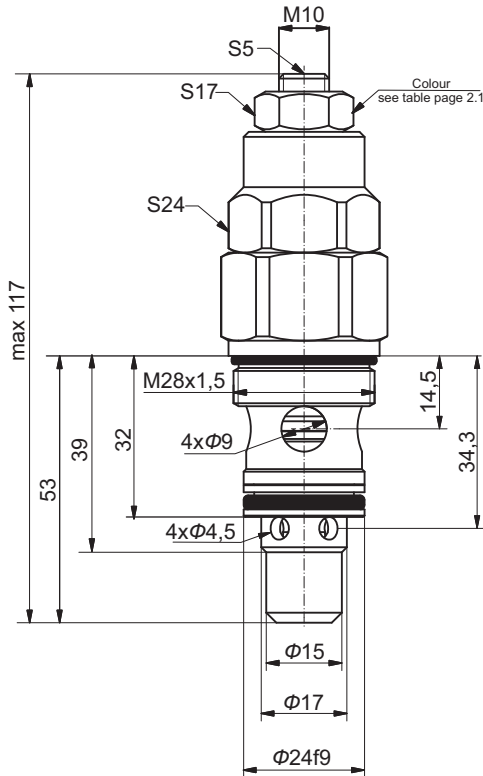

Code	Adjustment
A	Leakproof hex. socket screw
B	Handknob and locknut
C	Sealing cap

Code	Pressure range		Colour
	Adj. pressure range bar	Standard setting (Q=5 L/min) bar	
10	10...100	80	White
25	30...250	180	Yellow
35	70...350	250	Black

Type	P _{max} bar	Q _{max} L/min
KPZ12/..	350	100

- Note:** 1. All performances and calibrations are carried out by using hydraulic oil with viscosity approx. 32 cSt at 50°C
2. Tightening torque: 45 N.m.
3. Body coating – Zn.
4. Working fluid: Viscosity - 10...100 mm²/s. Temperature range:-20°C...+80°C. Filtration absolute: 25 µm.

ORDERING CODE

KPZ 12 / 10 A





**Hidro
Pnevmo
Tehnika**

3, Vojeli St., Kazanlak, Bulgaria
Tel.: +359 431/ 62 228, 68 440
e-mail: info@hpt-bg.com
www.hpt-bg.com

CARTRIDGE RELIEF VALVE

KPPZ 10-1/..

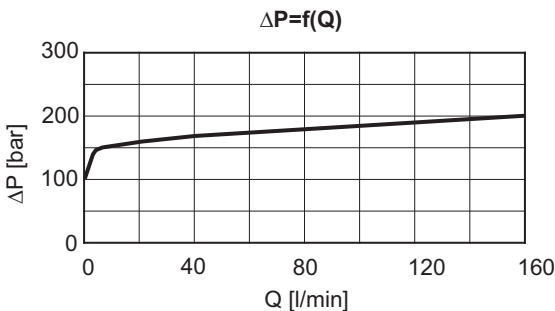
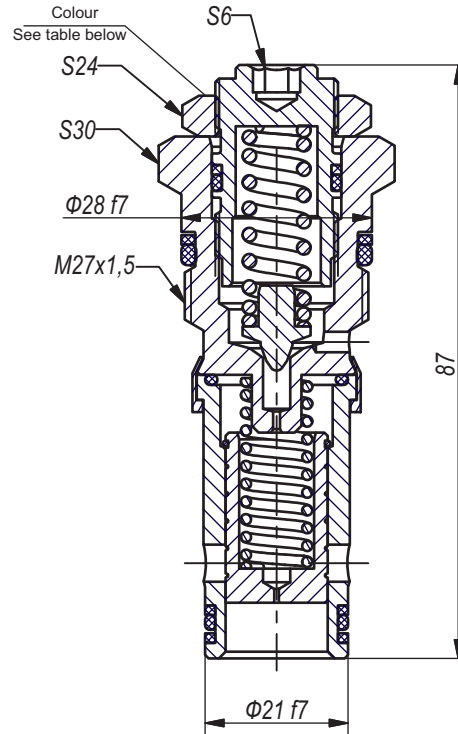
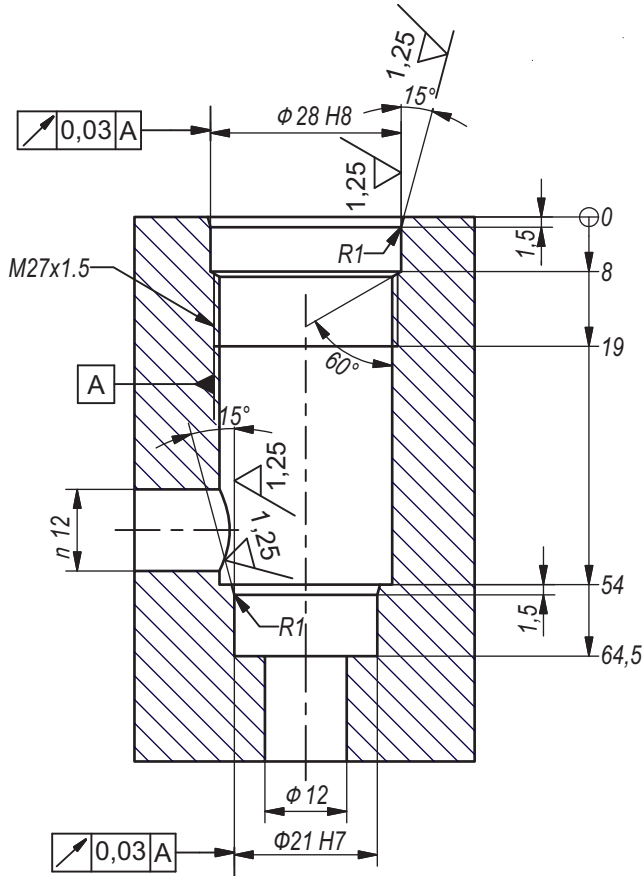

Type	$P_{max.}$ bar	$Q_{nom.}$ L/min
KPPZ10-1/..	350	160

Code	Pressure range		Colour
	Adj. pressure range bar	Standard setting ($Q=5$ L/min) bar	
10	5...100	80	White
20	15...200	180	Yellow
35	20...350	250	Black

Note: 1. All performances and calibrations are carried out by using hydraulic oil with viscosity approx. 46 cSt at 50°C
2. Tightening torque: 45 N.m.
3. Working fluid: Viscosity - 10...100 mm²/s. Temperature range: -20°C...+80°C. Filtration absolute: 25 µm.

ORDERING CODE

KPPZ10-1 / 10

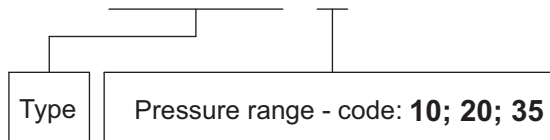

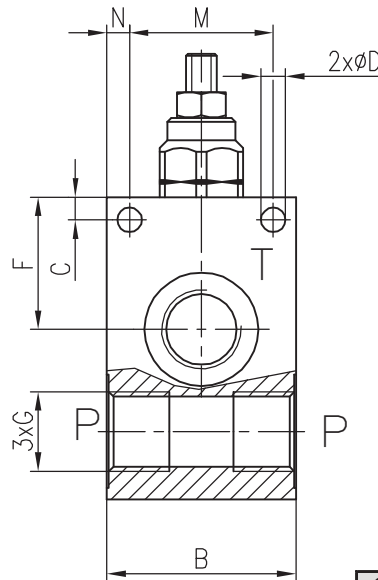
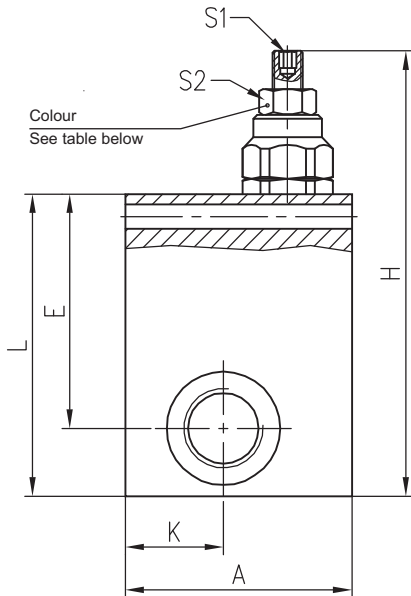
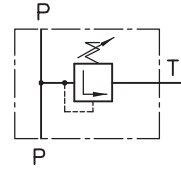

Code	Pressure range		Colour
	Adj. pressure range bar	Standard setting (Q=5 L/min) bar	
10	10...100	80	White
25	30...250	180	Yellow
35	70...350	250	Black

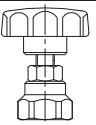
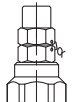
Code	Adjustment
A	Leakproof hex. socket screw 
B	Handknob and locknut 
C	Sealing cap 

Type	Q _{max} L/min	G	A	B	C	H	K	L	M	N	E	F	D	S1	S2
			mm	mm	mm	mm	mm	mm	mm	mm	mm	mm	mm	mm	mm
CPL 40/14	40	G 1/4	50	40	8	108	20	65	32	4	47	26	5,5	4	13
CPL 40/38		G 3/8													
CPL 40/12		G 1/2													
CPL 80/12	80	G 1/2	60	50	6	135	26	80	38	6	62	35	6,5	5	17
CPL 80/34		G 3/4									60	33			

Note: 1. All performances and calibrations are carried out by using hydraulic oil with viscosity approx. 46 cSt at 50°C
2. Tightening torque: 35 N.m.
3. Working fluid: Viscosity - 10...100 mm²/s. Temperature range: -20°C...+80°C. Filtration absolute: 25 µm.

ORDERING CODE

CPL 40 / 14 -10 A

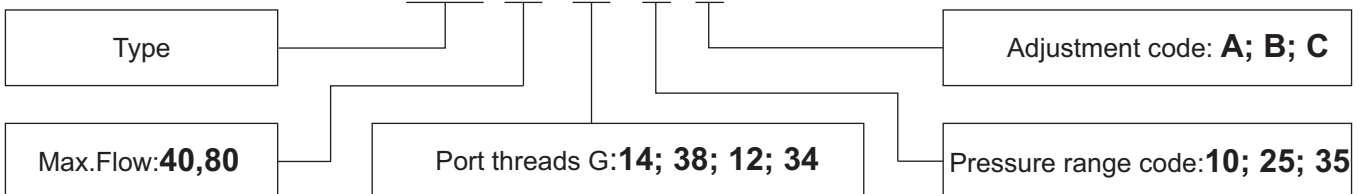



**Hidro
Pnevmo
Tehnika**

3, Vojeli St., Kazanlak, Bulgaria
Tel.: +359 431/ 62 228, 68 440
e-mail: info@hpt-bg.com
www.hpt-bg.com

RELIEF VALVE

CPL160/1-..

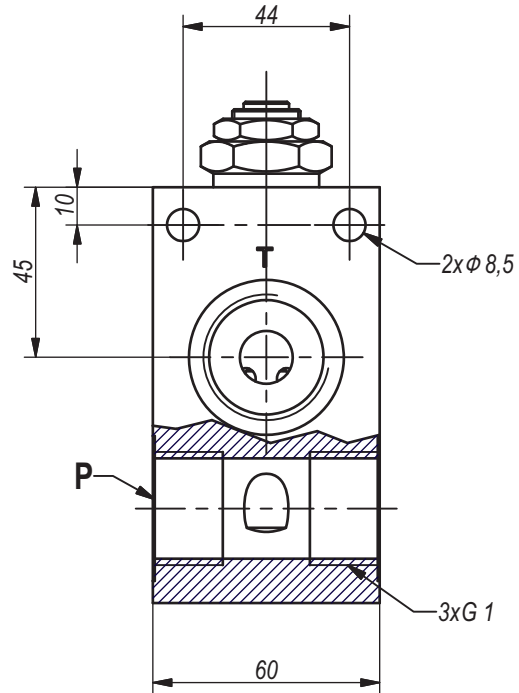
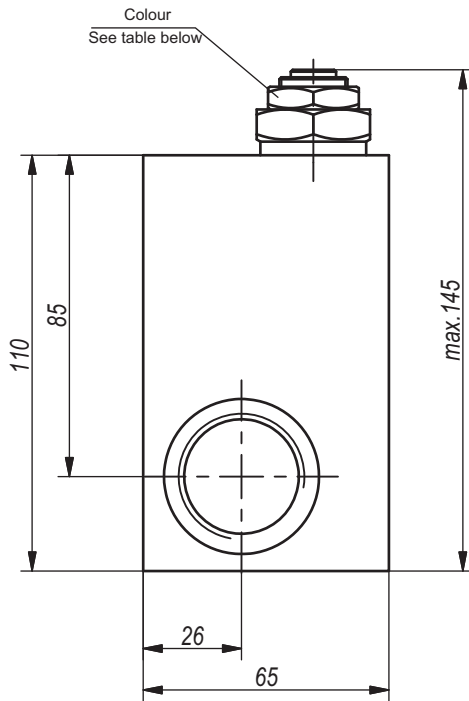
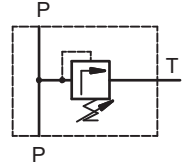

$\Delta P=f(Q)$

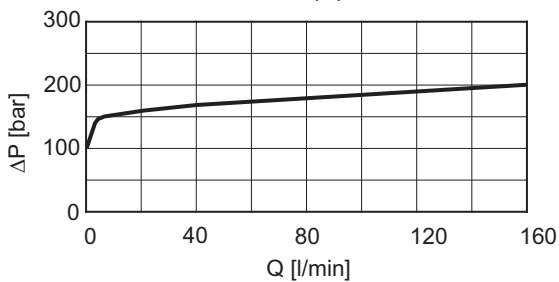

Type	P _{max.} bar	Q _{nom.} L/min
CPL160/1-..	320	160

Code	Pressure range		Colour
	Adj. pressure range bar	Standard setting (Q=5 L/min) bar	
10	5...100	80	White
20	15...200	180	Yellow
32	20...320	250	Black

Note: 1. All performances and calibrations are carried out by using hydraulic oil with viscosity approx. 46 cSt at 50°C
2. Working fluid: Viscosity - 10...100 mm²/s. Temperature range:-20°C...+80°C. Filtration absolute: 25 µm.

ORDERING CODE

CPL160/1 - ..

Type

Pressure range code: **10 , 20 , 32**



**Hidro
Pnevmo
Tehnika**

3, Vojeli St., Kazanlak, Bulgaria
Tel.: +359 431/ 62 228, 68 440
e-mail: info@hpt-bg.com
www.hpt-bg.com

RELIEF VALVE

RV-NS32/...-...

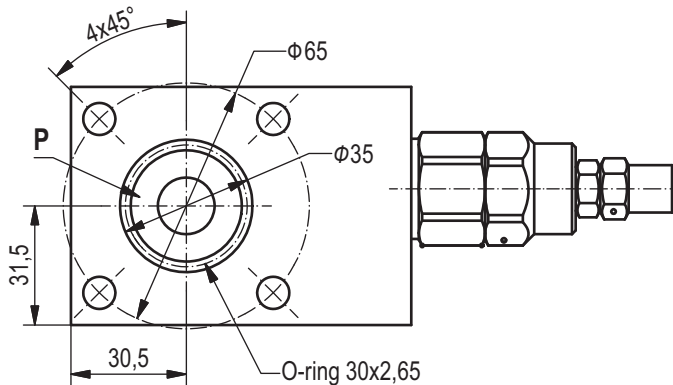
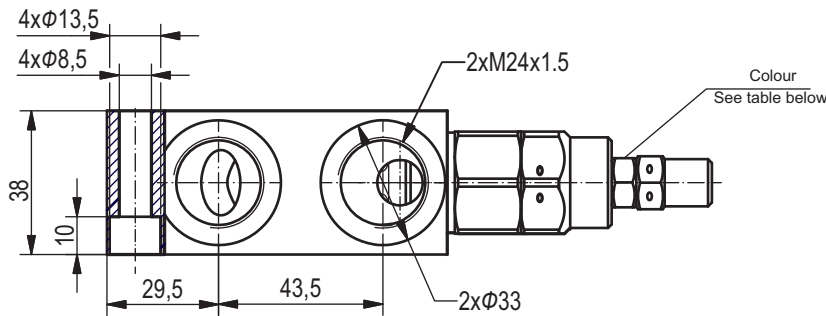
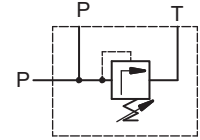
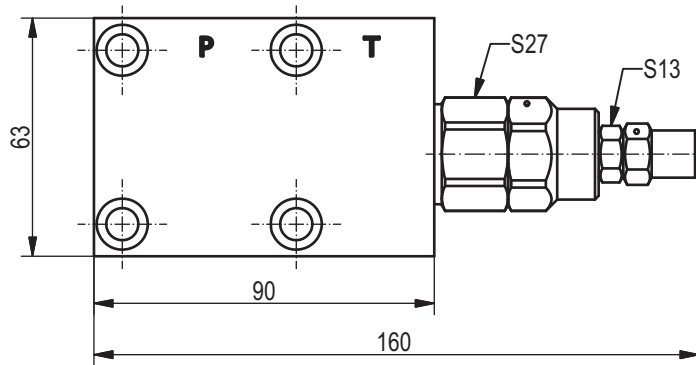
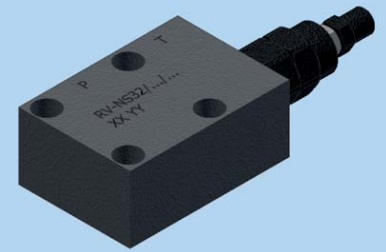

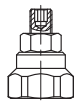
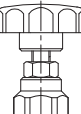
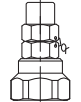
Code	Adjustment
A	Leakproof hex. socket screw 
B	Handknob and locknut 
C	Sealing cap 

Type	P _{max.} bar	Q _{nom.} L/min
RV-NS32/10/...	100	60
RV-NS32/25/...	250	60

Code	Pressure range		Colour
	Adj. pressure range	Standard setting (Q=5 L/min)	
10	10...100	80	White
25	30...250	180	Yellow

Note: 1. All performances and calibrations are carried out by using hydraulic oil with viscosity approx. 46 cSt at 50°C
2. Working fluid: Viscosity - 10...100 mm²/s. Temperature range:-20°C...+80°C. Filtration absolute: 25 µm.

ORDERING CODE

