



**Hidro  
Pnevmo  
Tehnika**

3, Vojeli St., Kazanlak, Bulgaria  
Tel.: +359 431/ 62 228, 68 440  
e-mail: info@hpt-bg.com  
www.hpt-bg.com

## CARTRIDGE RELIEF VALVE

### KPPZ 10-1/..

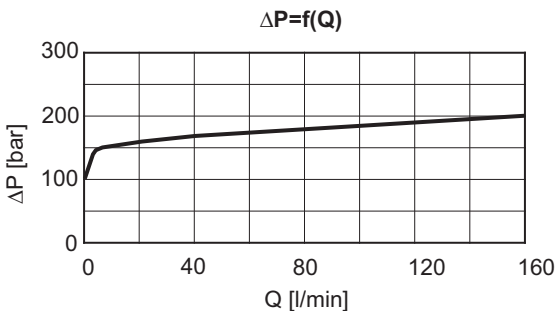
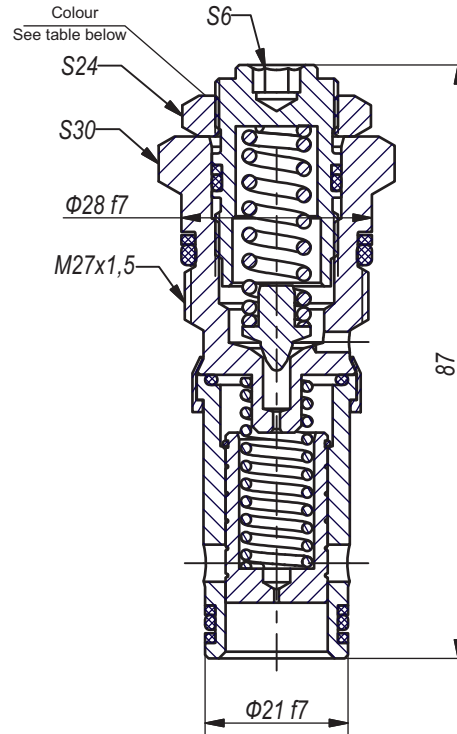
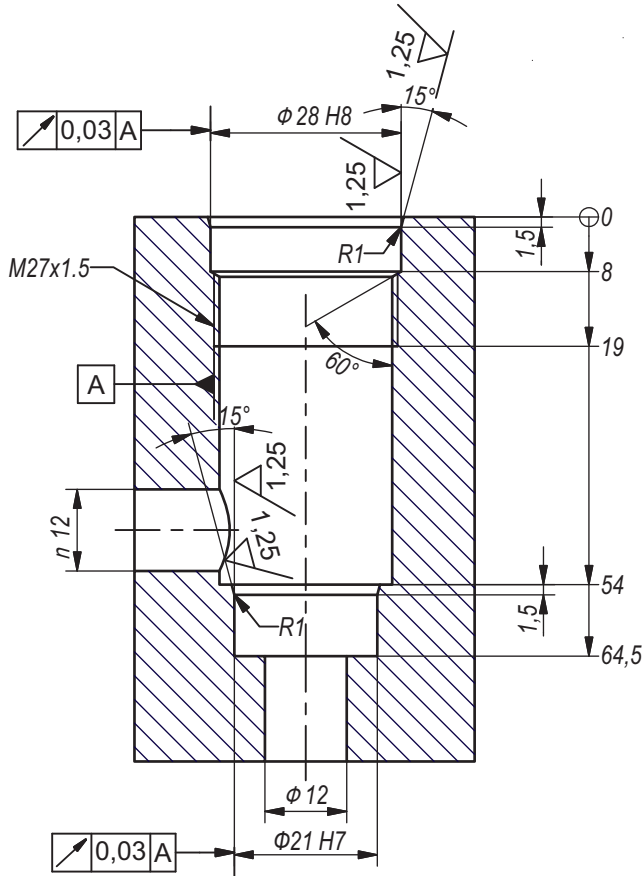

Type	$P_{max.}$ bar	$Q_{nom.}$ L/min
KPPZ10-1/..	350	160

Code	Pressure range		Colour
	Adj. pressure range bar	Standard setting ( $Q=5$ L/min) bar	
10	5...100	80	White
20	15...200	180	Yellow
35	20...350	250	Black

**Note:** 1. All performances and calibrations are carried out by using hydraulic oil with viscosity approx. 46 cSt at 50°C  
2. Tightening torque: 45 N.m.  
3. Working fluid: Viscosity - 10...100 mm<sup>2</sup>/s. Temperature range: -20°C...+80°C. Filtration absolute: 25 µm.

## ORDERING CODE

**KPPZ10-1 / 10**

