



**Hidro
Pnevmo
Tehnika**

3, Vojeli St., Kazanlak, Bulgaria
Tel.: +359 431/ 62 228, 68 440
e-mail: info@hpt-bg.com
www.hpt-bg.com

CARTRIDGE RELIEF VALVE

KPZ ... / ...



KPZ 12/.. A

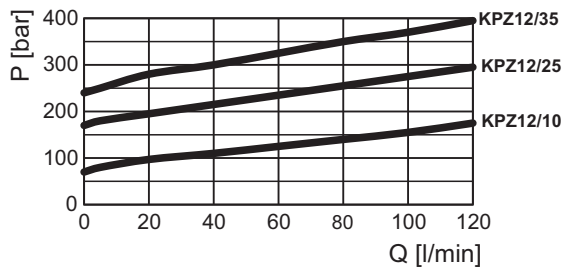
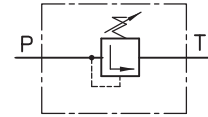
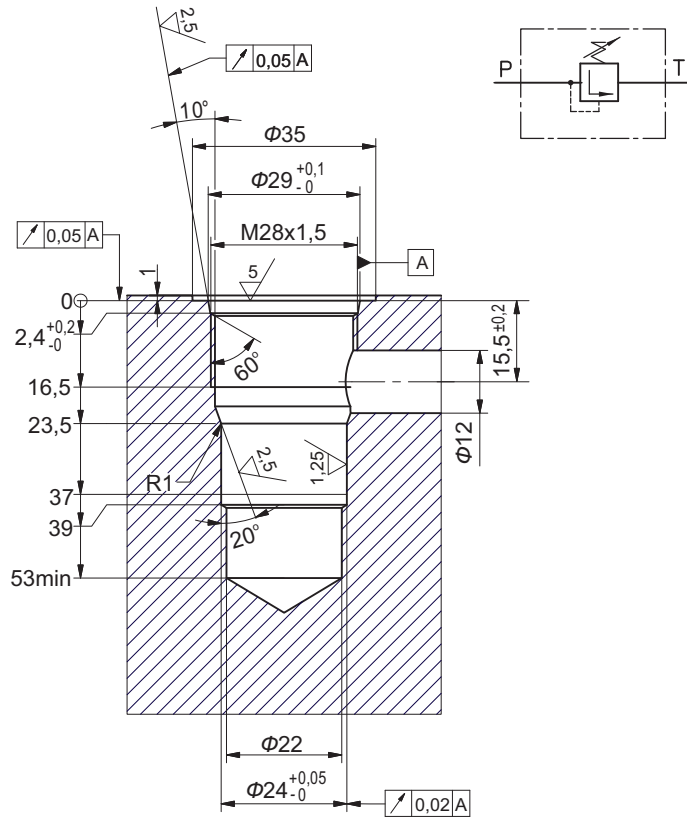
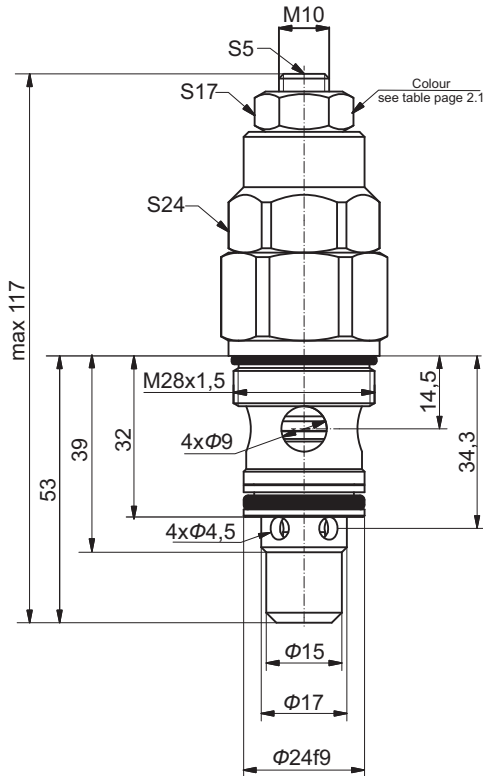

Code	Adjustment
A	Leakproof hex. socket screw
B	Handknob and locknut
C	Sealing cap

Code	Pressure range		Colour
	Adj. pressure range bar	Standard setting (Q=5 L/min) bar	
10	10...100	80	White
25	30...250	180	Yellow
35	70...350	250	Black

Type	P _{max} bar	Q _{max} L/min
KPZ12/..	350	100

- Note:** 1. All performances and calibrations are carried out by using hydraulic oil with viscosity approx. 32 cSt at 50°C
 2. Tightening torque: 45 N.m.
 3. Body coating – Zn.
 4. Working fluid: Viscosity - 10...100 mm²/s. Temperature range:-20°C...+80°C. Filtration absolute: 25 µm.

ORDERING CODE

KPZ 12 / 10 A

