



**Hidro  
Pnevmo  
Tehnika**

3, Vojeli St., Kazanlak, Bulgaria  
Tel.: +359 431/ 62 228, 68 440  
e-mail: info@hpt-bg.com  
www.hpt-bg.com

## CARTRIDGE RELIEF VALVE

**KPZ .. / ..**



### KPZ 10/.. A

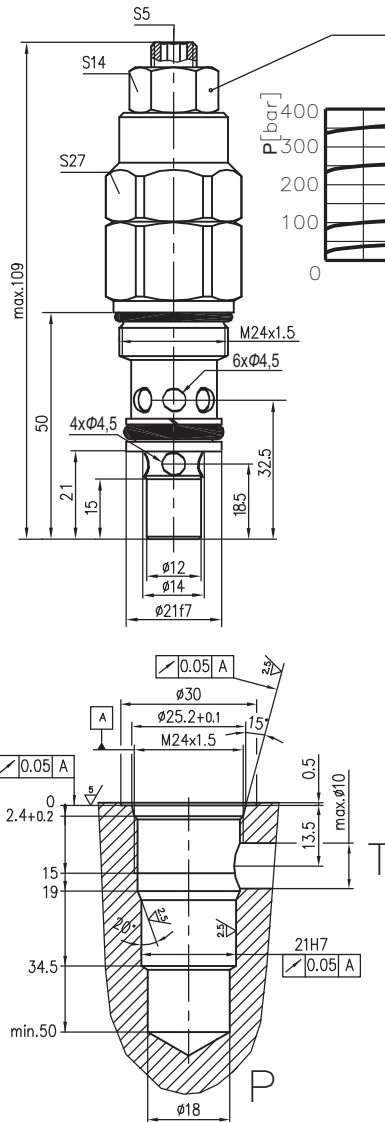

### KPZ 6/.. A

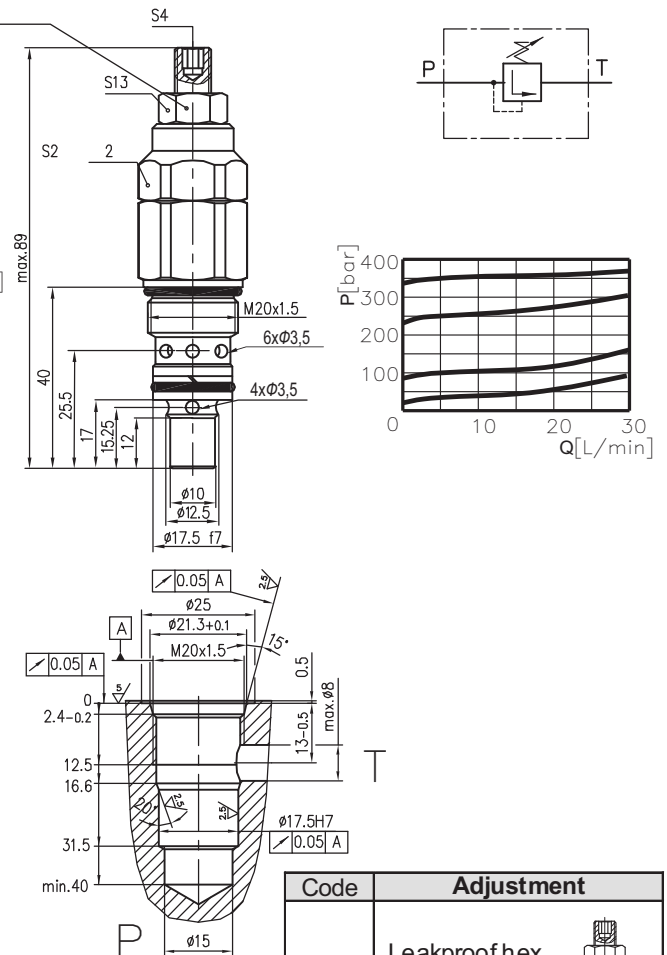

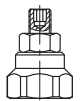
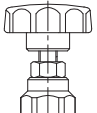
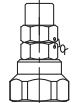
Code	Adjustment
<b>A</b>	Leakproof hex. socket screw 
<b>B</b>	Handknob and locknut 
<b>C</b>	Sealing cap 

Type	P <sub>max</sub> bar	Q <sub>max</sub> L/min
KPZ6/..	350	40
KPZ10/..	350	80

Code	Pressure range		Colour
	Adj. pressure range bar	Standard setting (Q=5 L/min) bar	
<b>10</b>	10...100	80	White
<b>25</b>	30...250	180	Yellow
<b>35</b>	70...350	250	Black

**Note:** 1. All performances and calibrations are carried out by using hydraulic oil with viscosity approx. 32 cSt at 50°C  
2. Tightening torque: 35 N.m.  
3. Body coating – Zn.  
4. Working fluid: Viscosity - 10...100 mm<sup>2</sup>/s. Temperature range:-20°C...+80°C. Filtration absolute: 25 µm.

### ORDERING CODE

**KPZ 6 / 10 A**

Type

Pressure range code: **10; 25; 35**

Adjustment code: **A; B; C**